

NOTICE DE MONTAGE · ASSEMBLING INSTRUCTION · MONTAGEANLEITUNG · MONTAGEHANDLEIDING

## Rail Grange · Barn Rail · Schiene Scheune · Rail met zichtbare wielen

Porte coulissante · Sliding door · Schiebetür · Schuifdeur

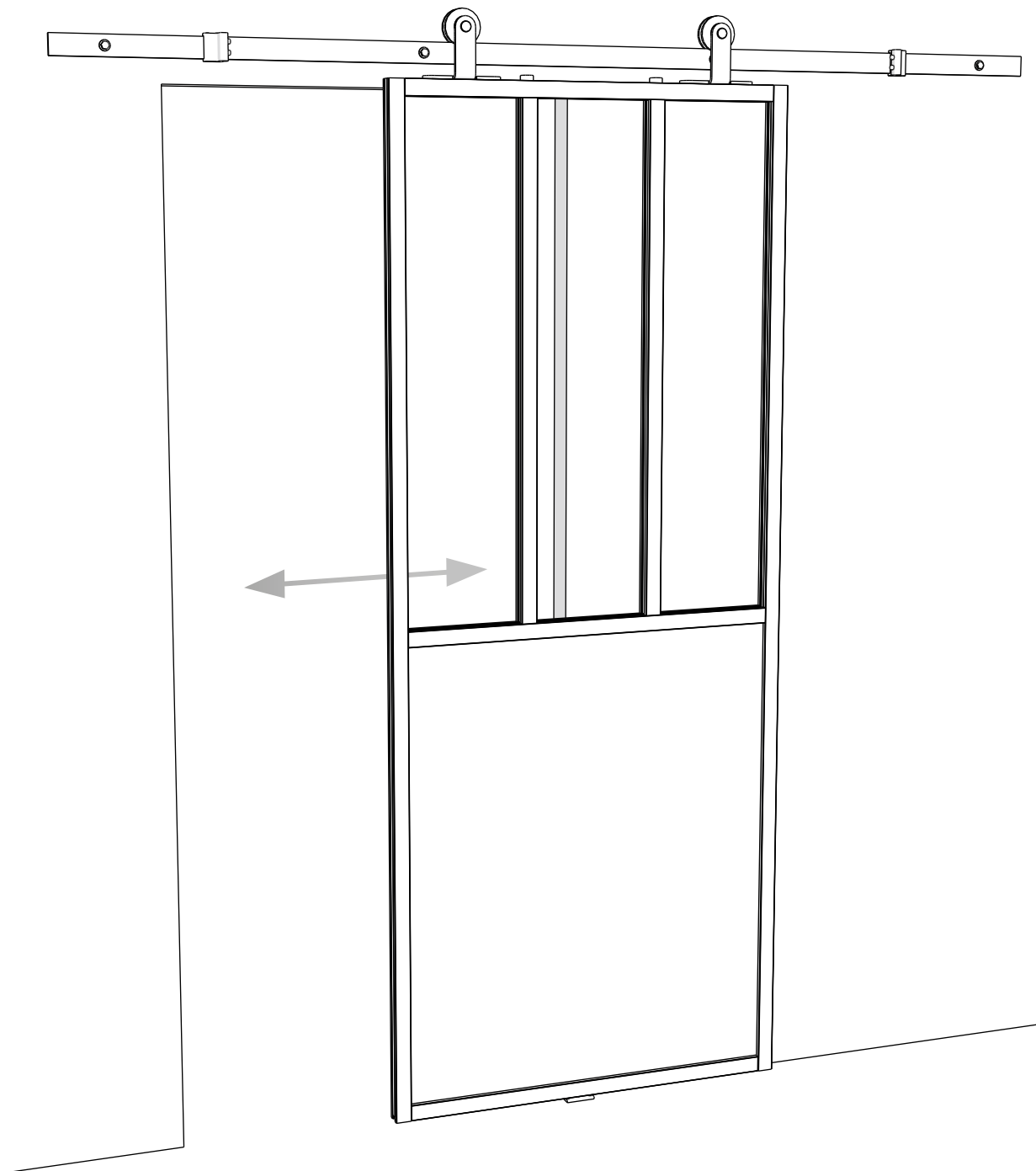

MATÉRIEL NÉCESSAIRE / NEEDED TOOLS / BENÖTIGTE WERKZEUGE / BENODIGD GEREEDSCHAP  
(non fourni / not provided / nicht im Lieferumfang enthalten / niet meegeleverd)

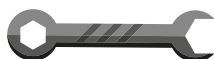
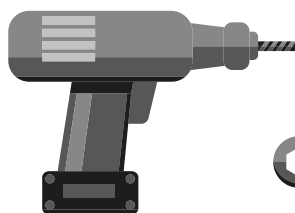

13 mm



Maillet  
Rubber mallet  
Gummihammer  
Rubberhamer

COMPOSITION DE VOTRE COLIS / INCLUDED IN THE PACKAGE / PAKETINHALT / INHOUD VAN DE VERPAKKING

**A**

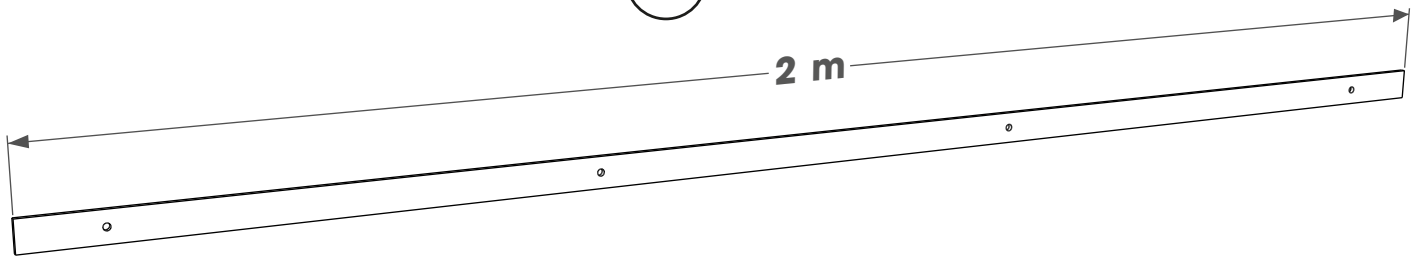

**B**

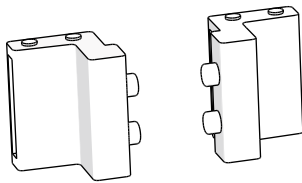

**C**

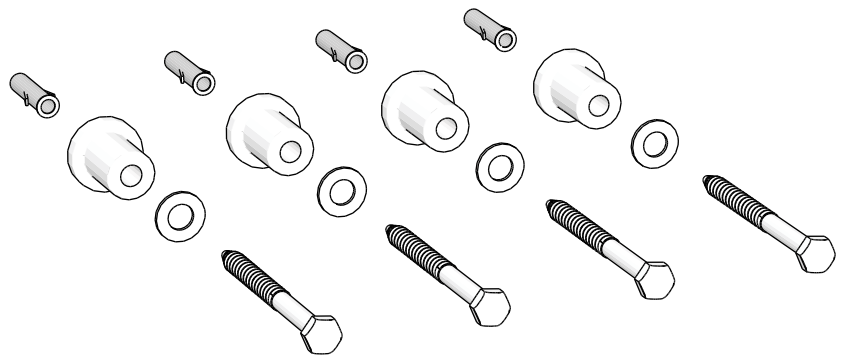

**D**

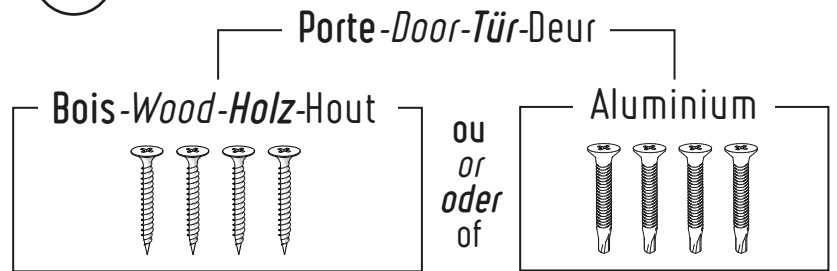
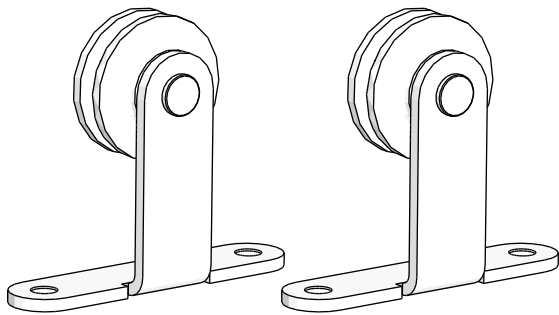

**E**

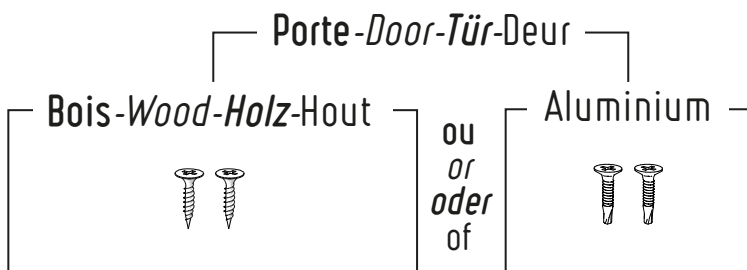

**F**

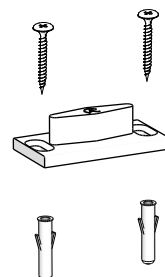

**G**



# ÉTAPE 1 - STEP 1 - SCHRITT 1 - STAP 1

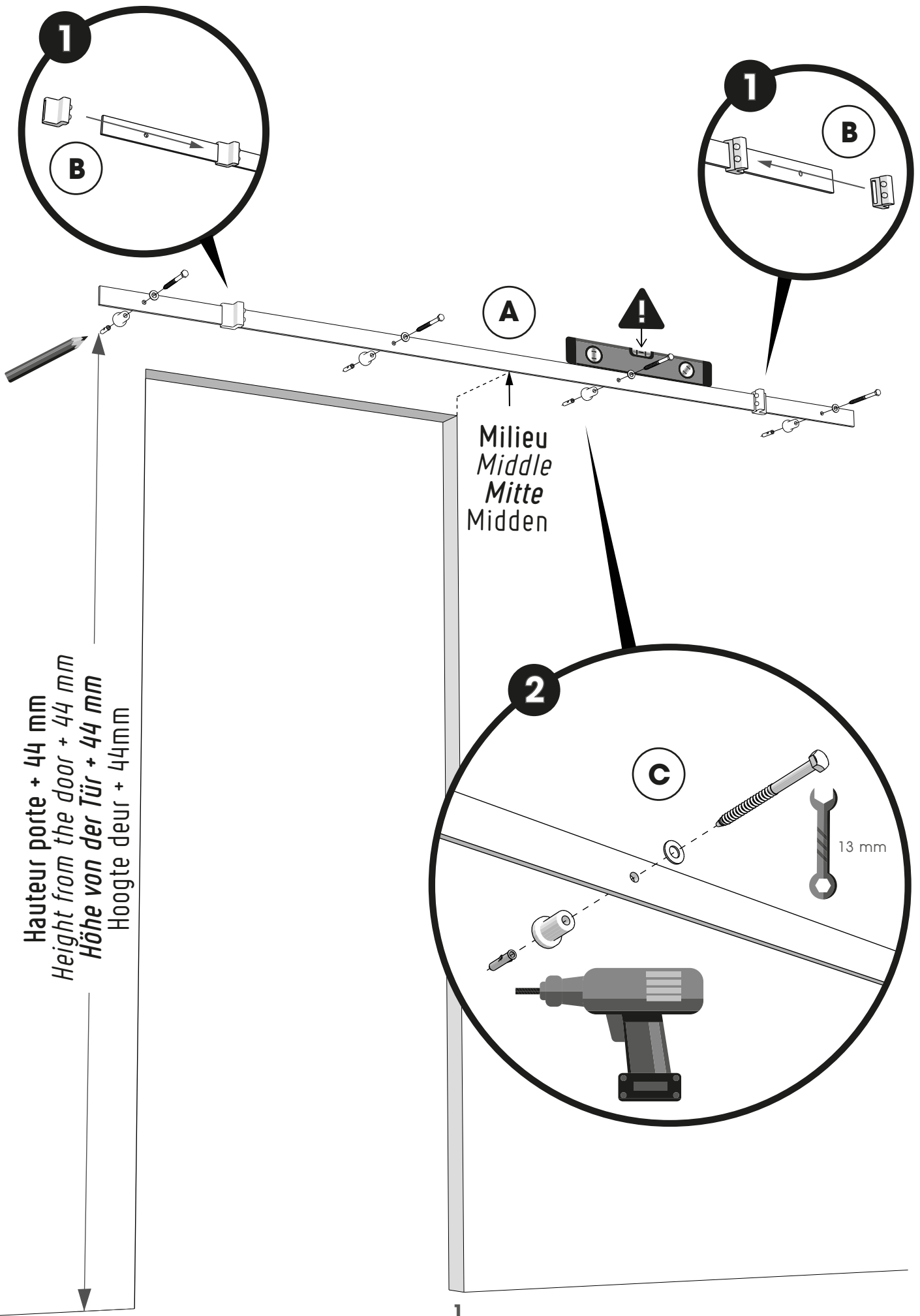

# ÉTAPE 2 - STEP 2 - SCHRITT 2 - STAP 2

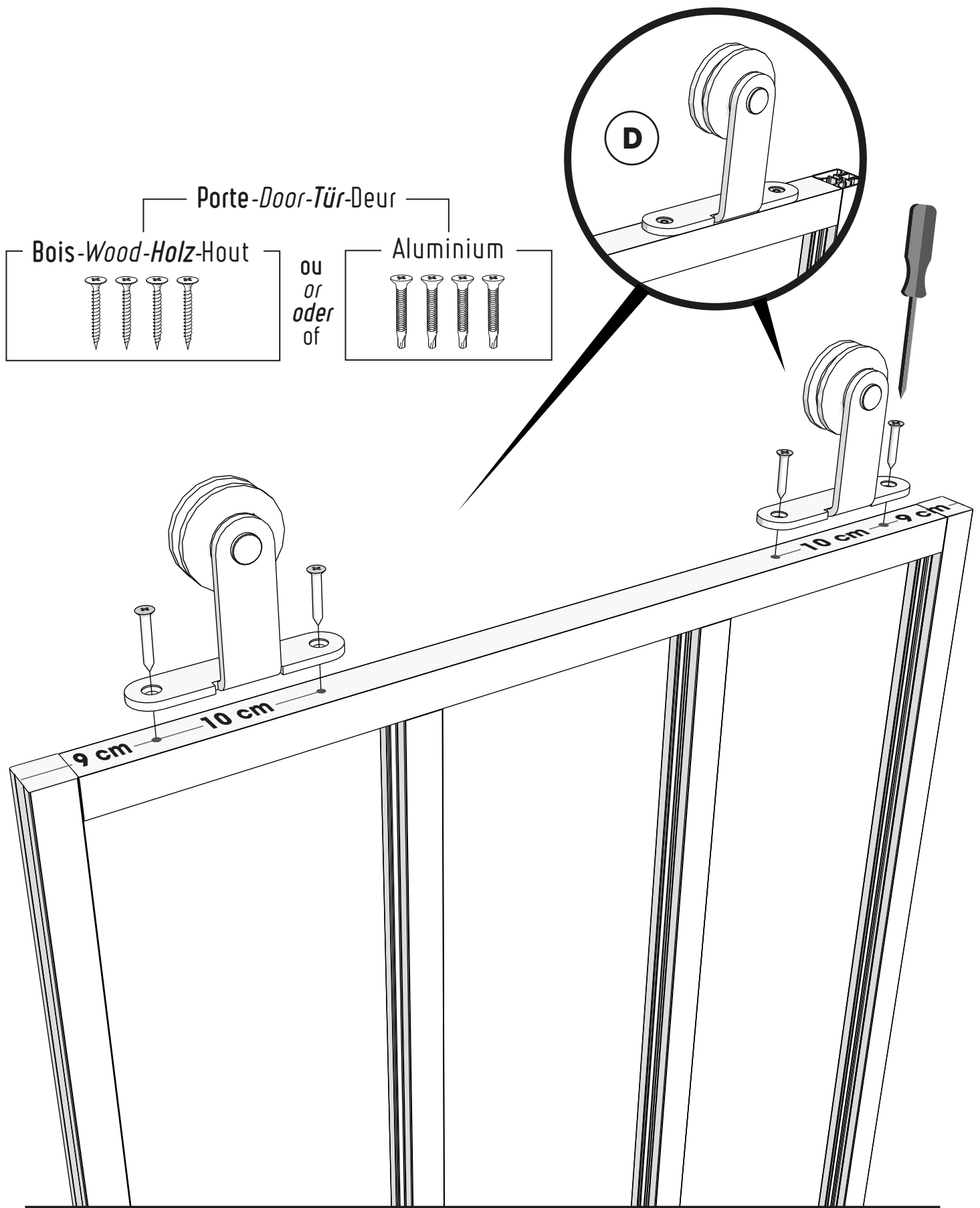

# ÉTAPE 3 - STEP 3 - SCHRITT 3 - STAP 3

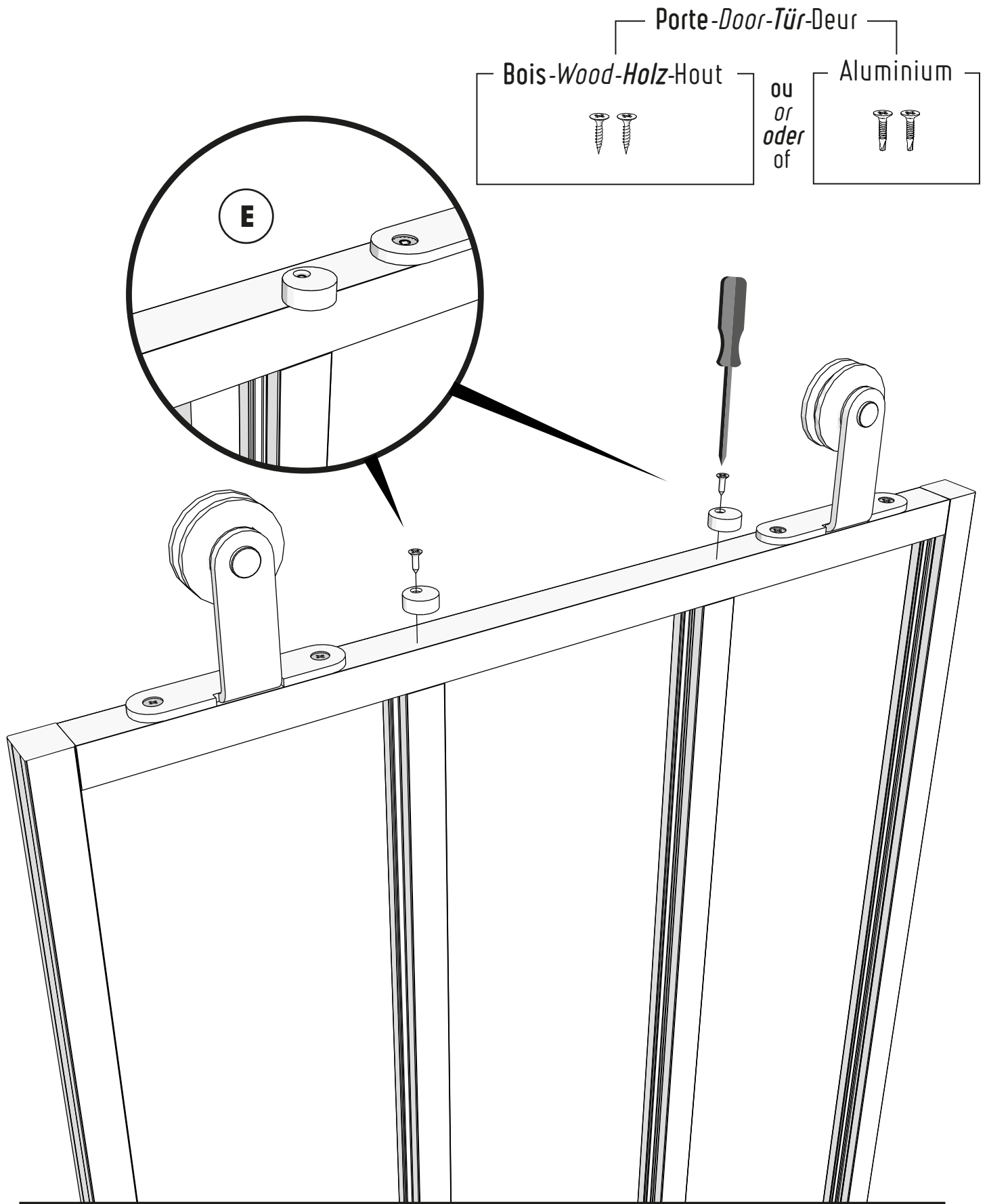

ÉTAPE 4 - STEP 4 - SCHRITT 4 - STAP 4

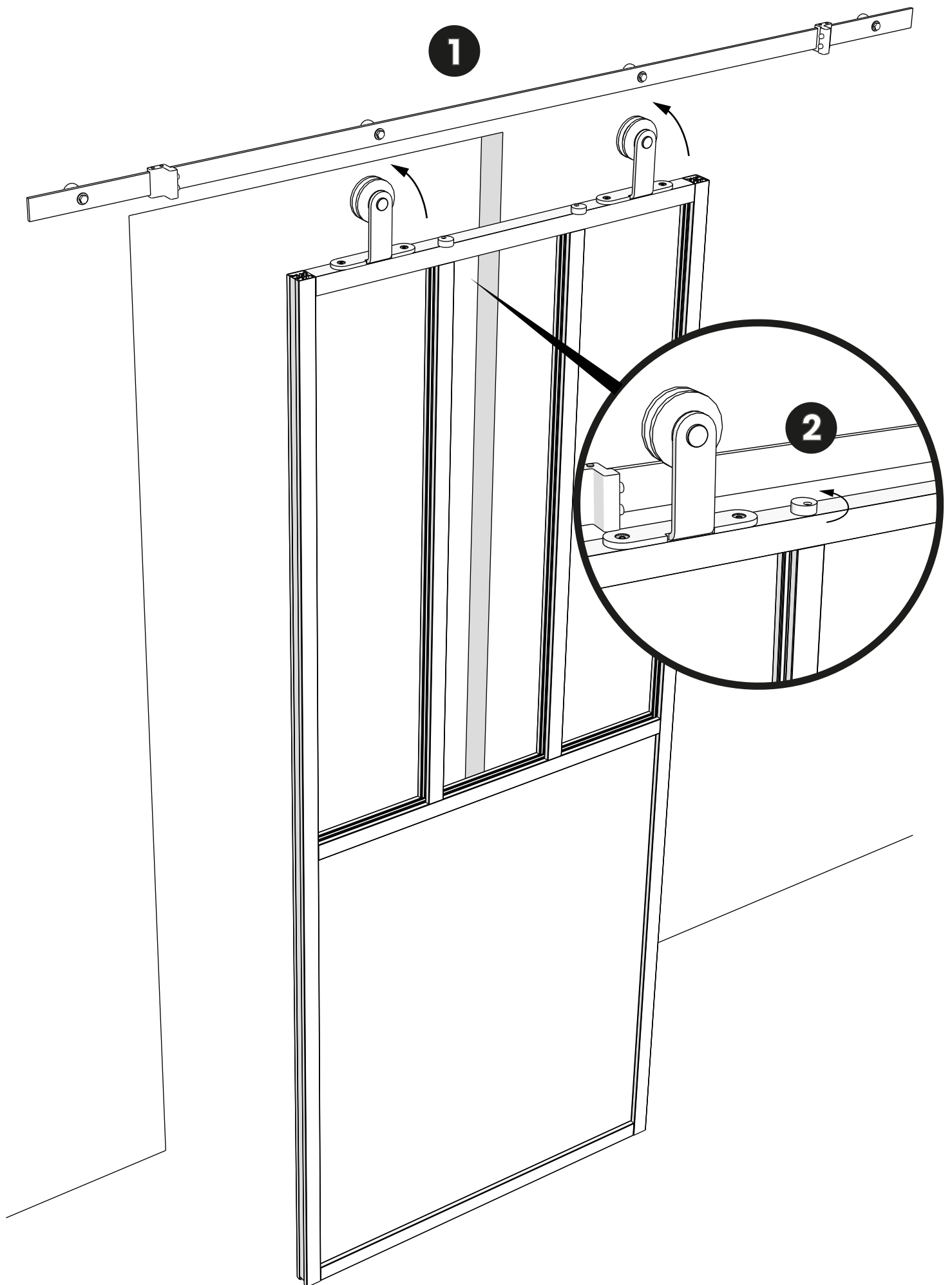

# ÉTAPE 5 - STEP 5 - SCHRITT 5 - STAP 5

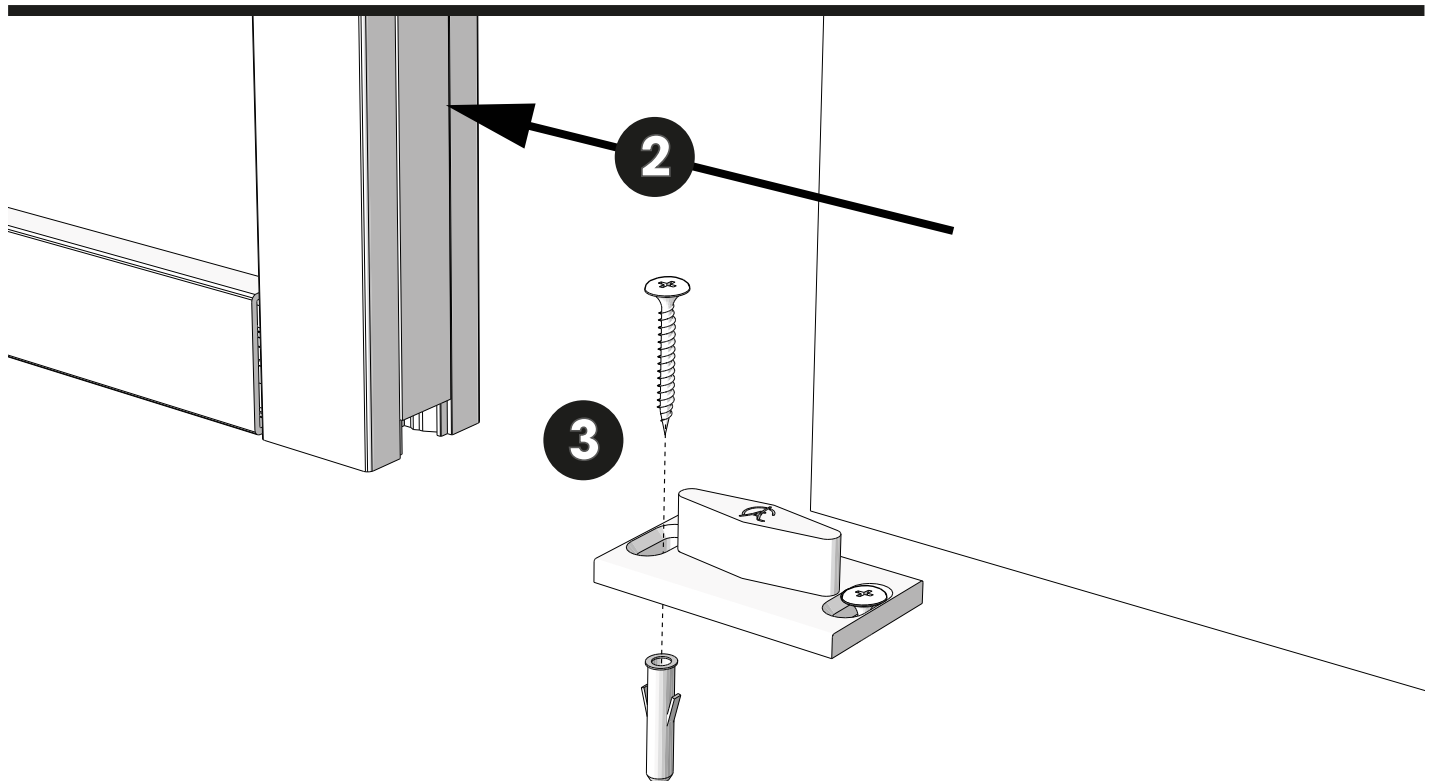
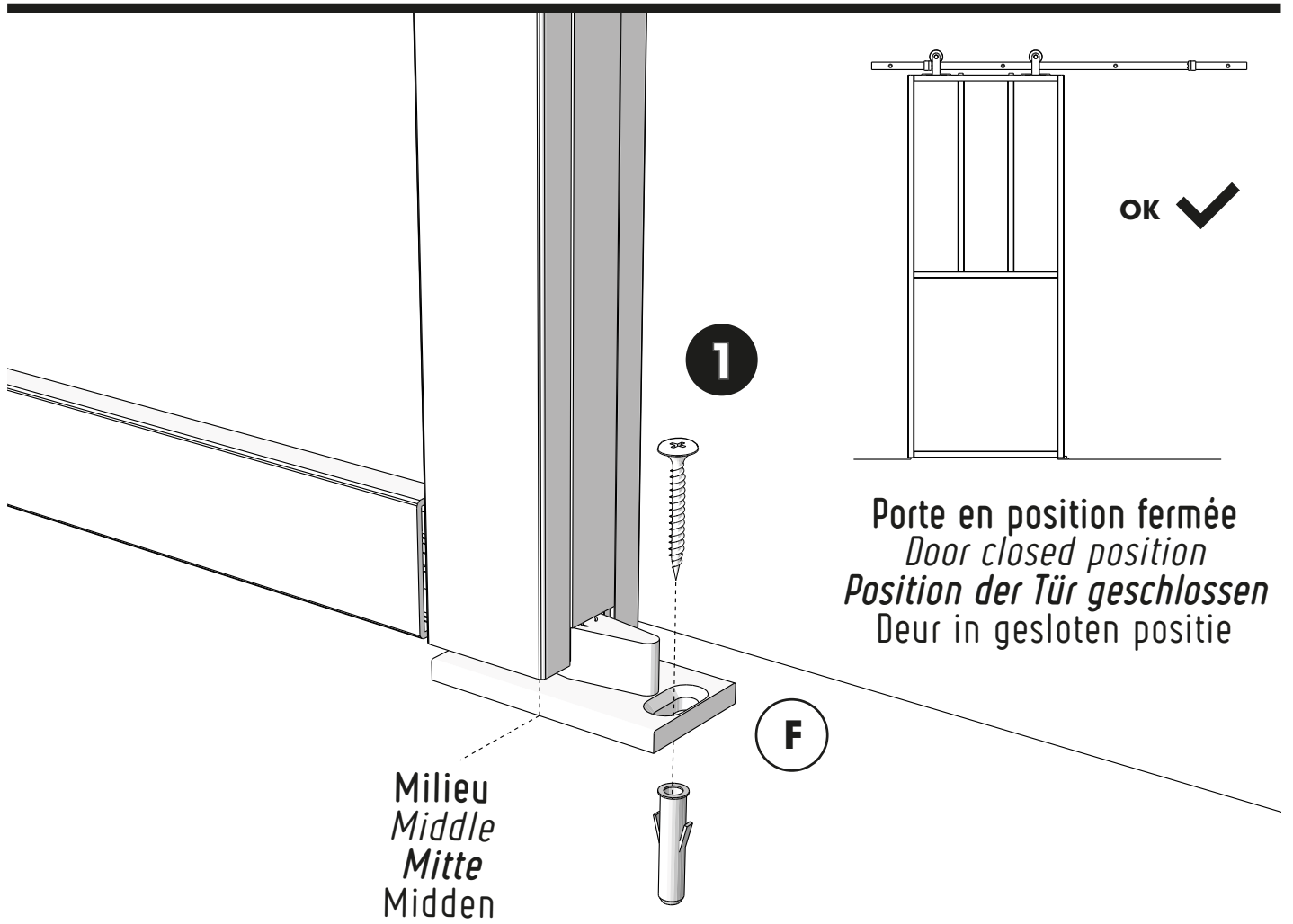

# ÉTAPE 6 - STEP 6 - SCHRITT 6 - STAP 6

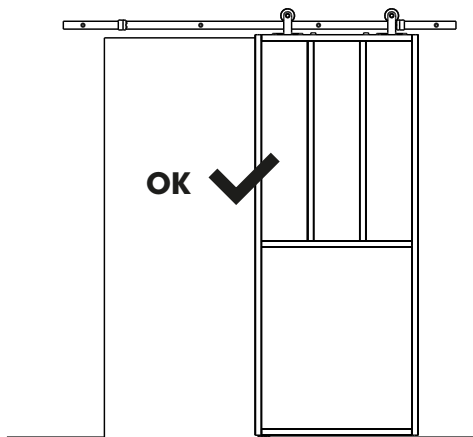

Porte en position ouverte  
*Door open position*  
Position der Tür offen  
Deur in open positie

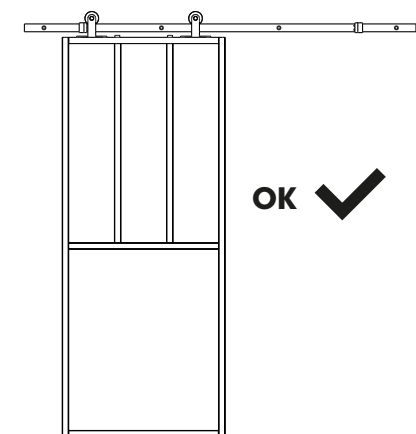
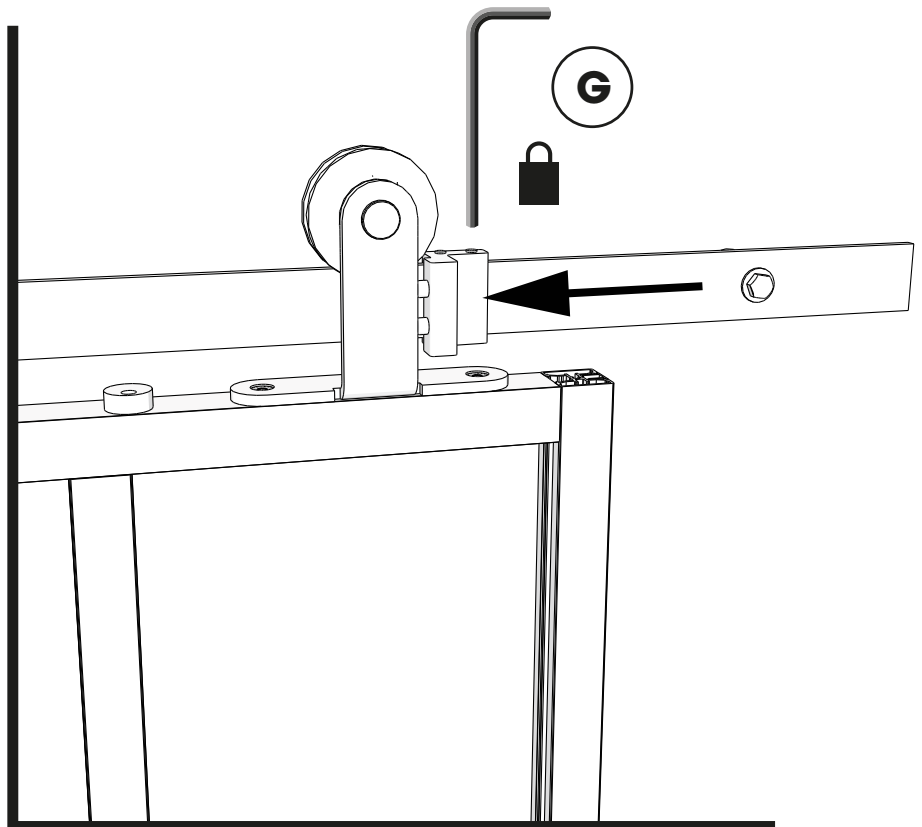

Porte en position fermée  
*Door closed position*  
Position der Tür geschlossen  
Deur in gesloten positie

