

Verrière - *Internal glass window* - *Glastrennwand* - Binnenraam

ORANGERIE

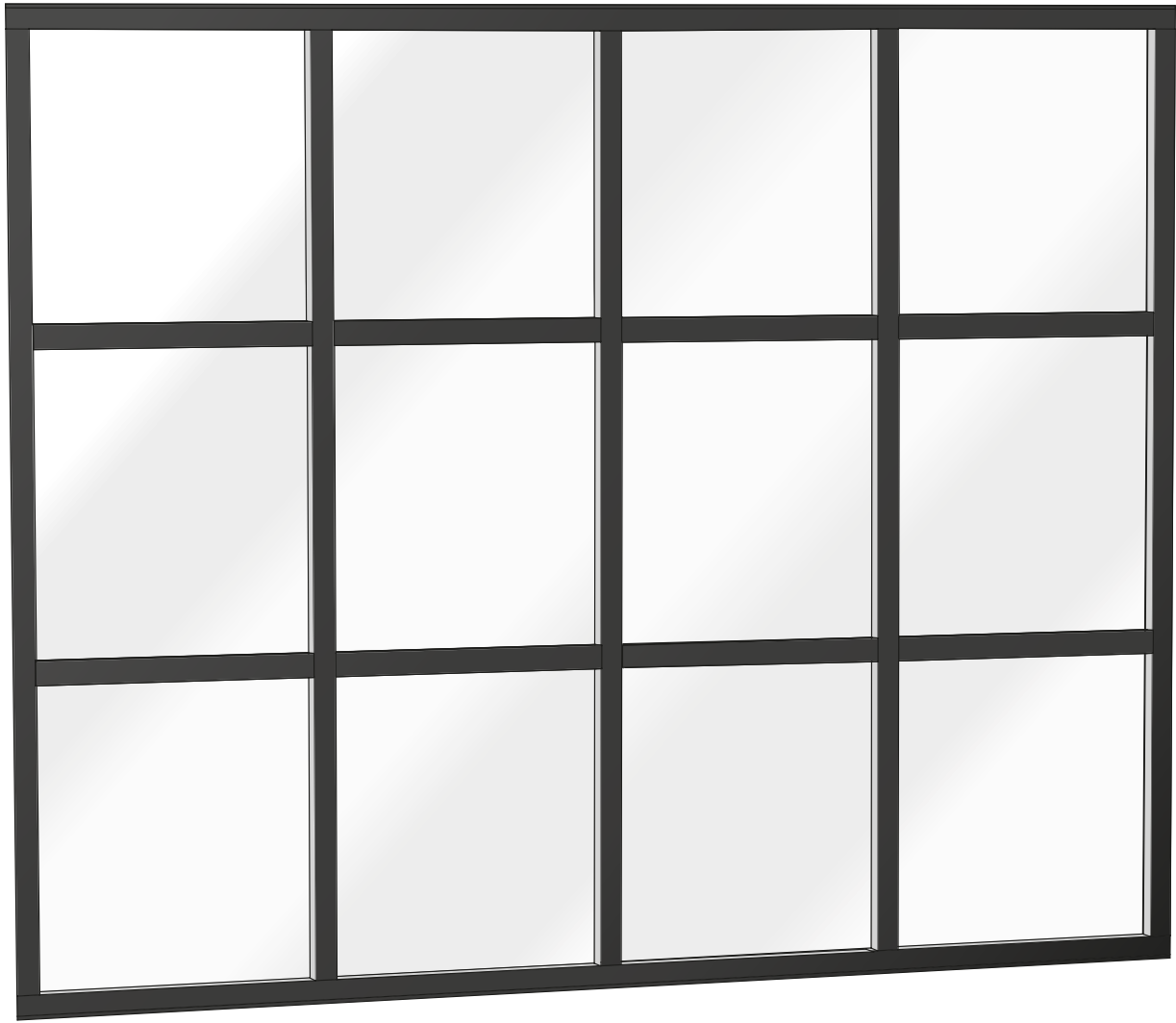

Ces instructions de montage s'appliquent à tous les modèles de verrière.

These assembly instructions apply to all glass windows.

Montageanleitung gilt für alle Glastrennwand-Ausführungen.





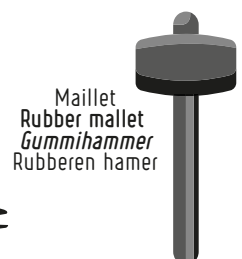
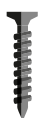
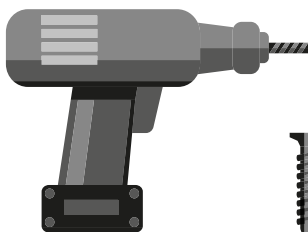

Deze plaatsingsinstructies gelden voor alle modellen binnenramen.

MATÉRIEL NÉCESSAIRE / *NEEDED TOOLS* / *BENÖTIGTE WERKZEUGE* / BENODIGD GEREEDSCHAP

(non fourni / not provided / *nicht im Lieferumfang enthalten* / niet meegeleverd)

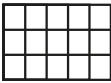
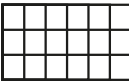
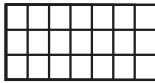
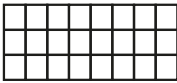
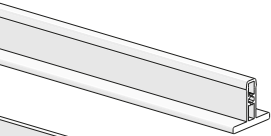
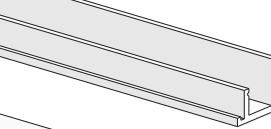
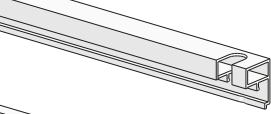
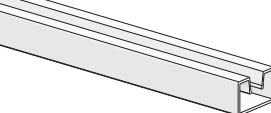
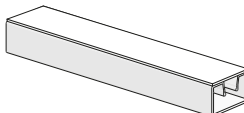
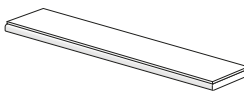
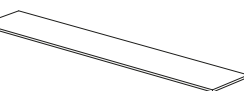

COMPOSITION DE VOTRE COLIS / INCLUDED IN THE PACKAGE /
PAKETINHALT / INHOUD VAN DE VERPAKKING

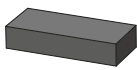
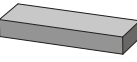
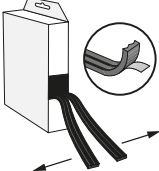
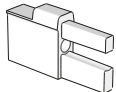
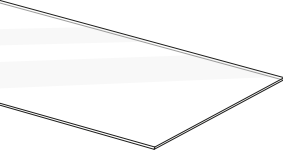
		x1	x2	x3	x4	x5	x6	x7	x8
									
	A Profil Profile Profil Profiel	x2	x3	x4	x5	x6	x7	x8	x9
	B Profil Profile Profil Profiel	x2	x2	x2	x2	x2	x2	x2	x2
	C Profil Profile Profil Profiel	x2	x2	x2	x2	x2	x2	x2	x2
	D Profil Profile Profil Profiel	x2	x3	x4	x5	x6	x7	x8	x9
	E Latte adhésive avant Front adhesive profile Vorderes Klebprofil Voorste zelfklevend profiel	x2	x4	x6	x8	x10	x12	x14	x16
	F Latte adhésive arrière back adhesive profile Hinteres Klebprofil Achterste zelfklevend profiel	x2	x4	x6	x8	x10	x12	x14	x16
	G Gabarit Spacer Abstandshalter Afstandshouders	x2	x2	x2	x2	x2	x2	x2	x2
	H Vis Screw Schraube schroef	x4	x6	x8	x10	x12	x14	x16	x18
	i Mousse adhésive Adhesive foam Klebschaum Zelfklevend schuim	x6	x6	x6	x6	x6	x6	x6	x6
	J Grande cale Large wooden block Großer Holzblock Grote houten blok	x2	x4	x6	x8	x10	x12	x14	x16
	K Joint adhésif Adhesive gasket Klebedichtung Zelfklevende afdichting	6m x1	6m x2	6m x3	6m x4	6m x5	6m x6	6m x7	6m x8
	L Insert Insert Verbindungsstück Invoegen	x4	x6	x8	x10	x12	x14	x16	x18
	M Vitrage Glazing Verglasung Glas	x1	x2	x3	x4	x5	x6	x7	x8

ÉTAPE 1 - STEP 1 - SCHRITT 1 - STAP 1

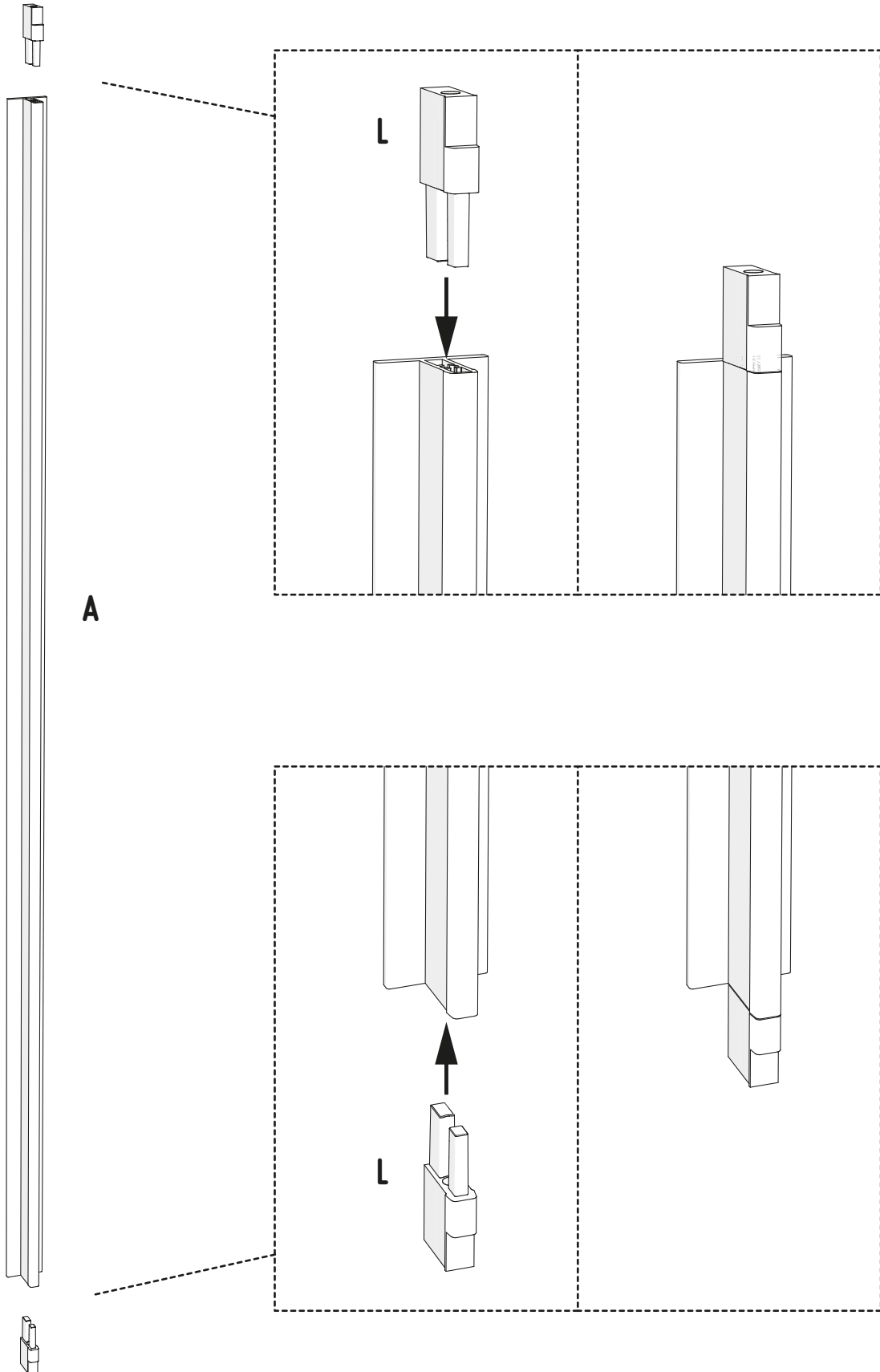

ÉTAPE 2 - STEP 2 - SCHRITT 2 - STAP 2

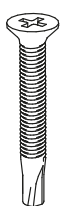
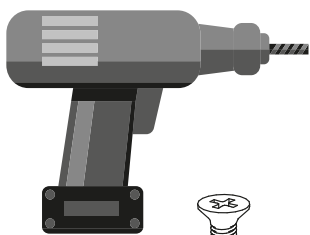
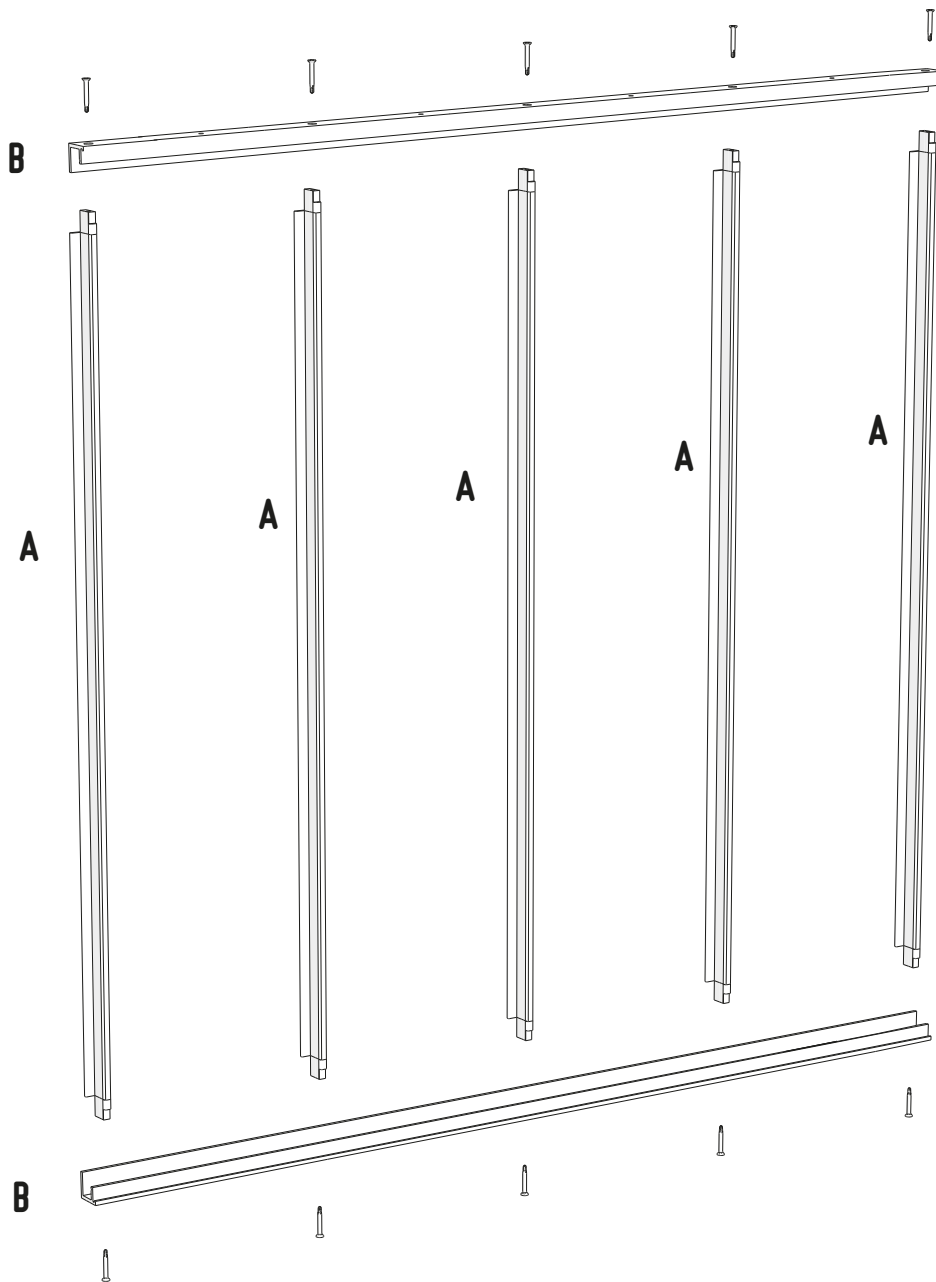

H

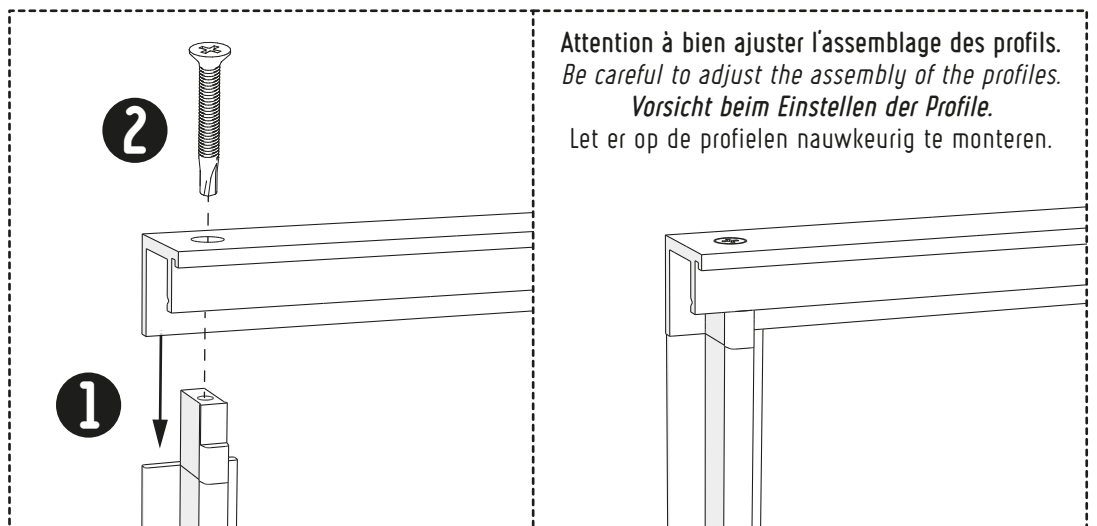

Attention à bien ajuster l'assemblage des profils.
Be careful to adjust the assembly of the profiles.
Vorsicht beim Einstellen der Profile.
Let er op de profielen nauwkeurig te monteren.

ÉTAPE 3 - STEP 3 - SCHRITT 3 - STAP 3

FR

Pour l'installation d'un poteau d'angle ou d'un poteau de terminaison, suivez la notice présente sur leur emballage. (Installation à effectuer avant la pose des mousses adhésives).

EN

To install the corner profile or the angle profile, please follow the instructions mentioned on the packaging. (installation to be done before the application of the adhesive foams).

DE

Zur Montage des Eckprofils oder des Abschlussprofils die Anweisungen auf der entsprechenden Verpackung beachten. (Vor dem Anbringen des Klebeschaums, müssen die Profile vorab montiert werden).

NL

Voor de installatie van een hoekprofiel of een eindprofiel, volg de instructies op de verpakking. (installeren vóór de plaatsing van de schuimblokjes)

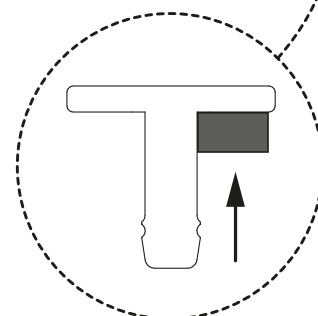
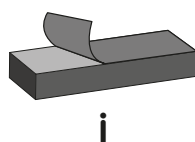
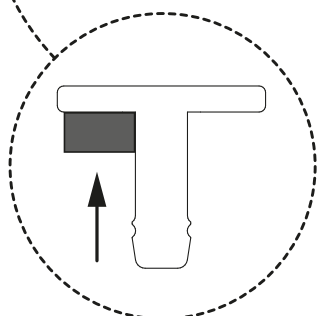
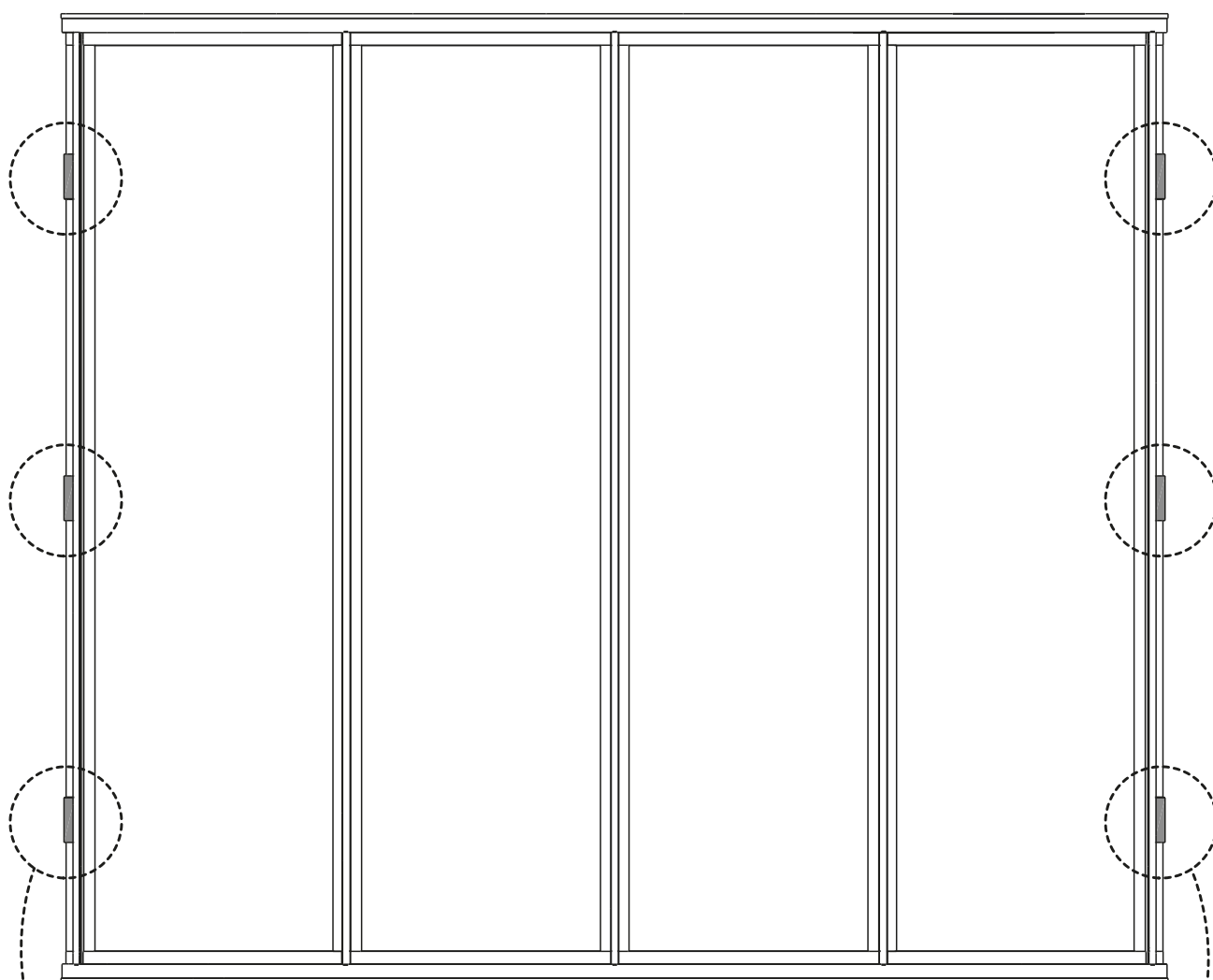
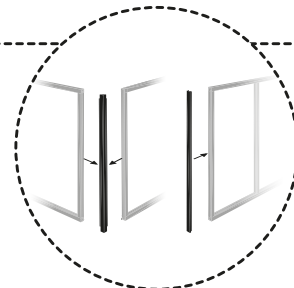

ÉTAPE 4 - STEP 4 - SCHRITT 4 - STAP 4

MUR / WALL / MAUER / MUUR

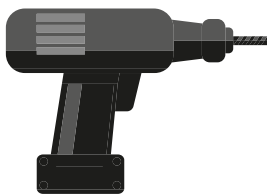
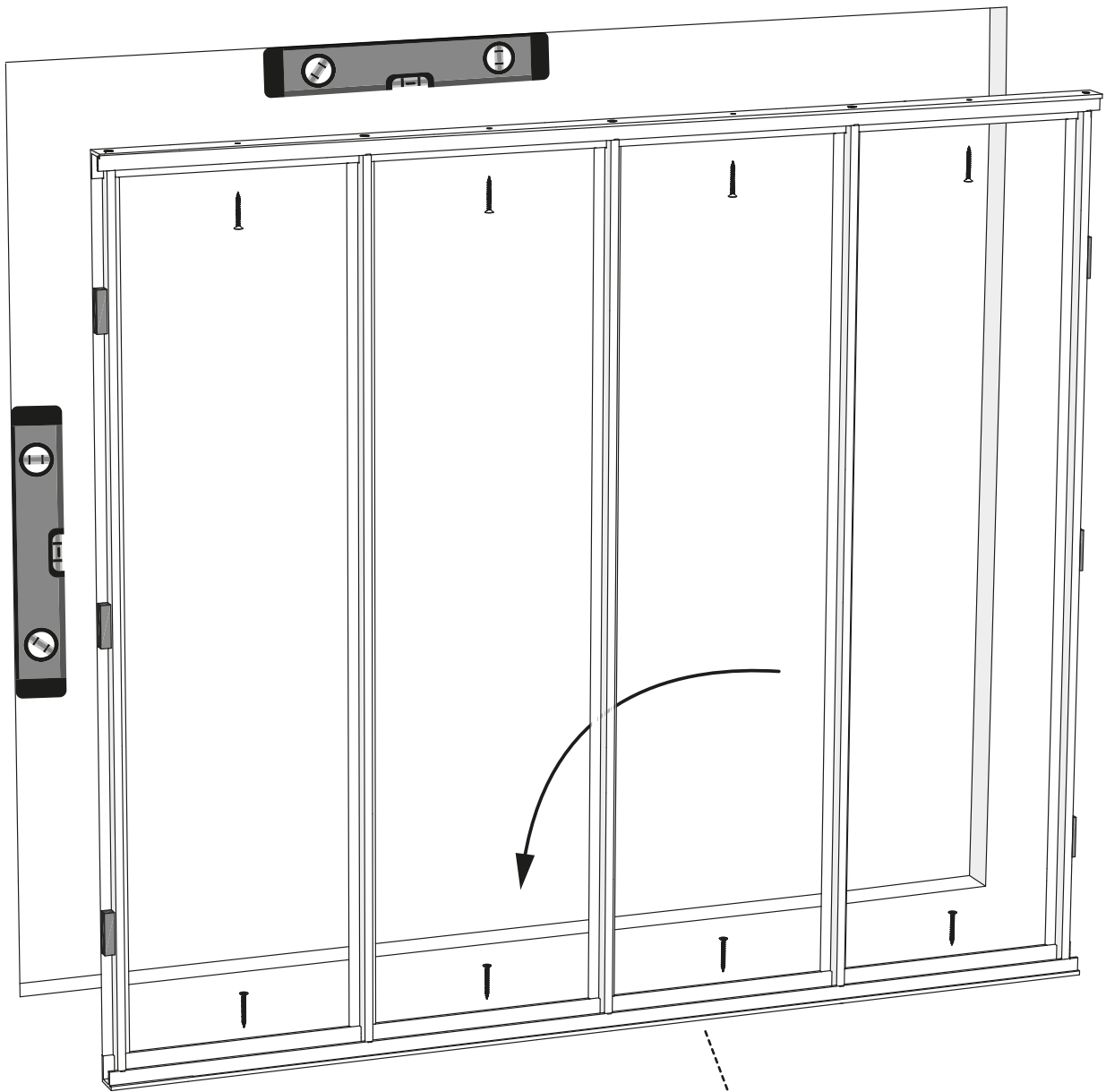

Vis (non fournies)
à adapter selon votre support.

Screw (not provided)
to adapt accordingly to your support.

Schrauben nicht im Lieferumfang enthalten.
Befestigung entsprechend dem Träger
(Holz, Beton, usw.) verwenden.

Schroeven (niet meegeleverd)
aan te passen volgens de wand.

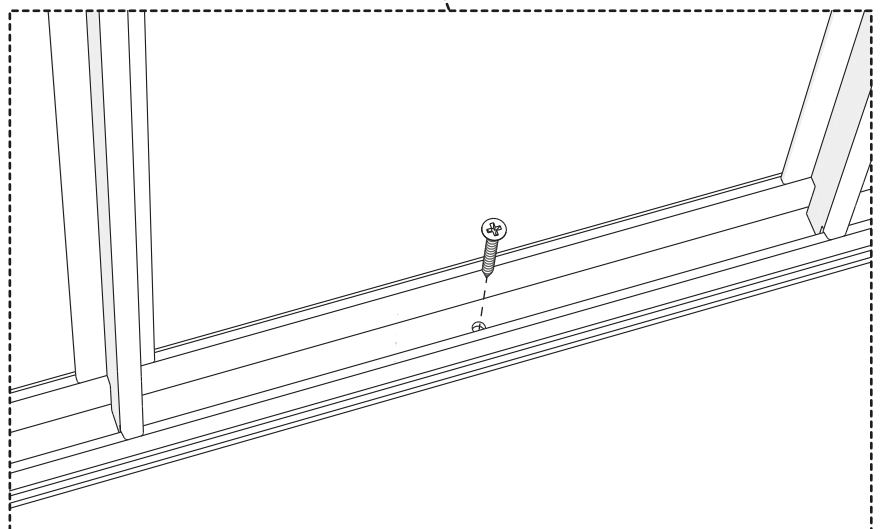

ÉTAPE 5 - STEP 5 - SCHRITT 5 - STAP 5

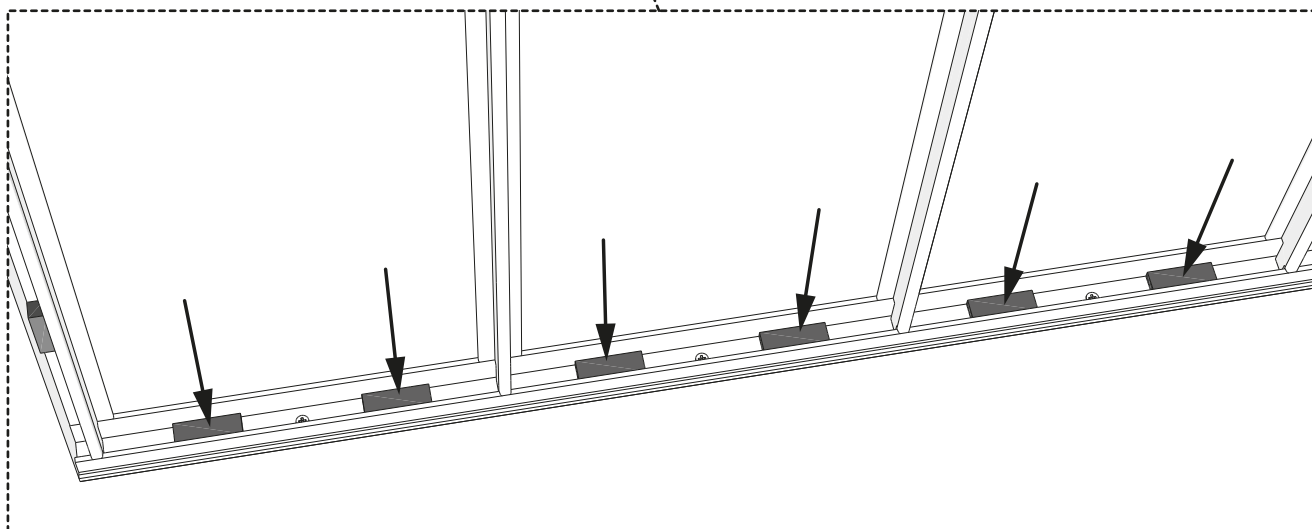
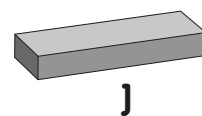
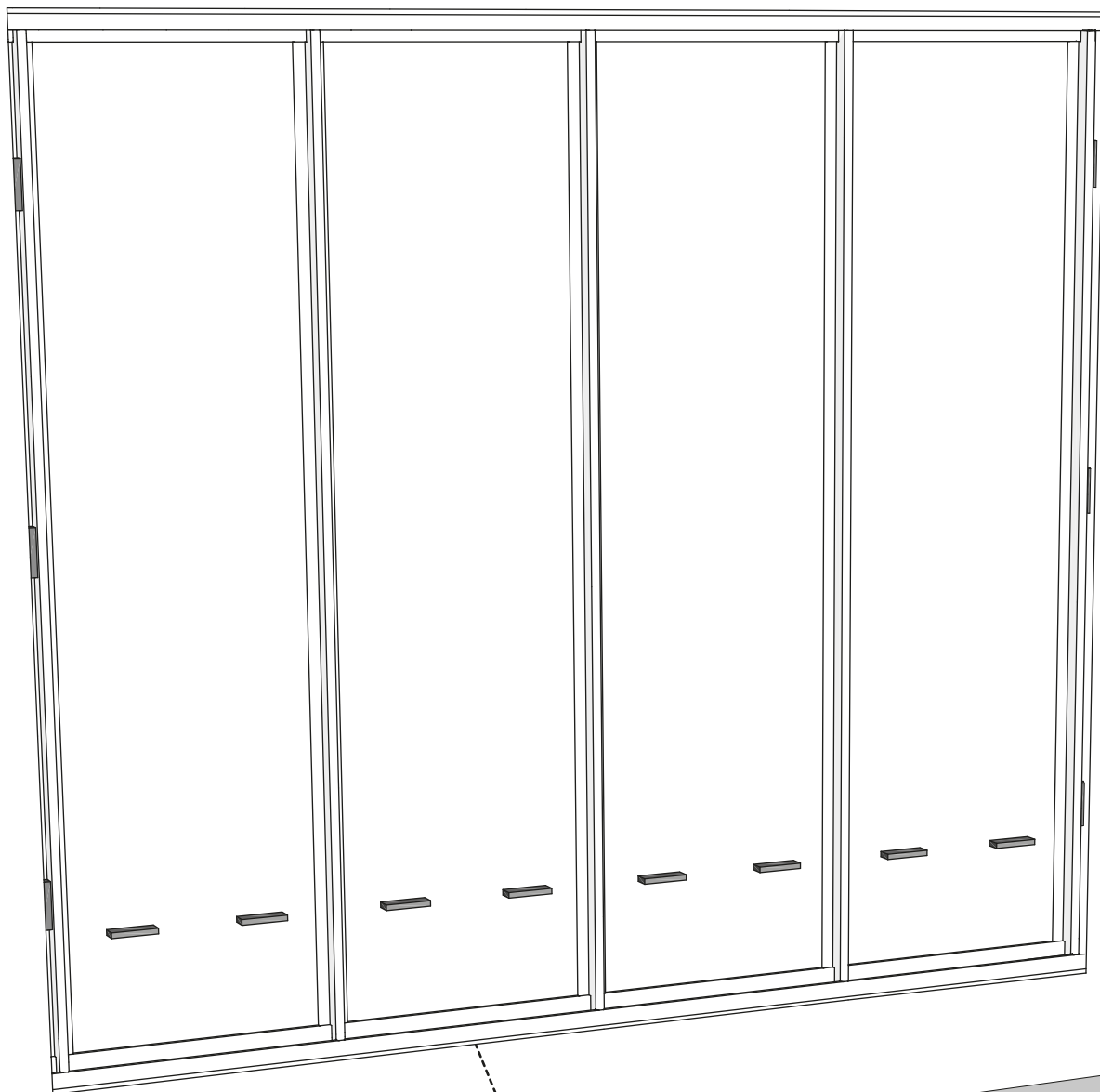

ÉTAPE 6 - STEP 6 - SCHRITT 6 - STAP 6

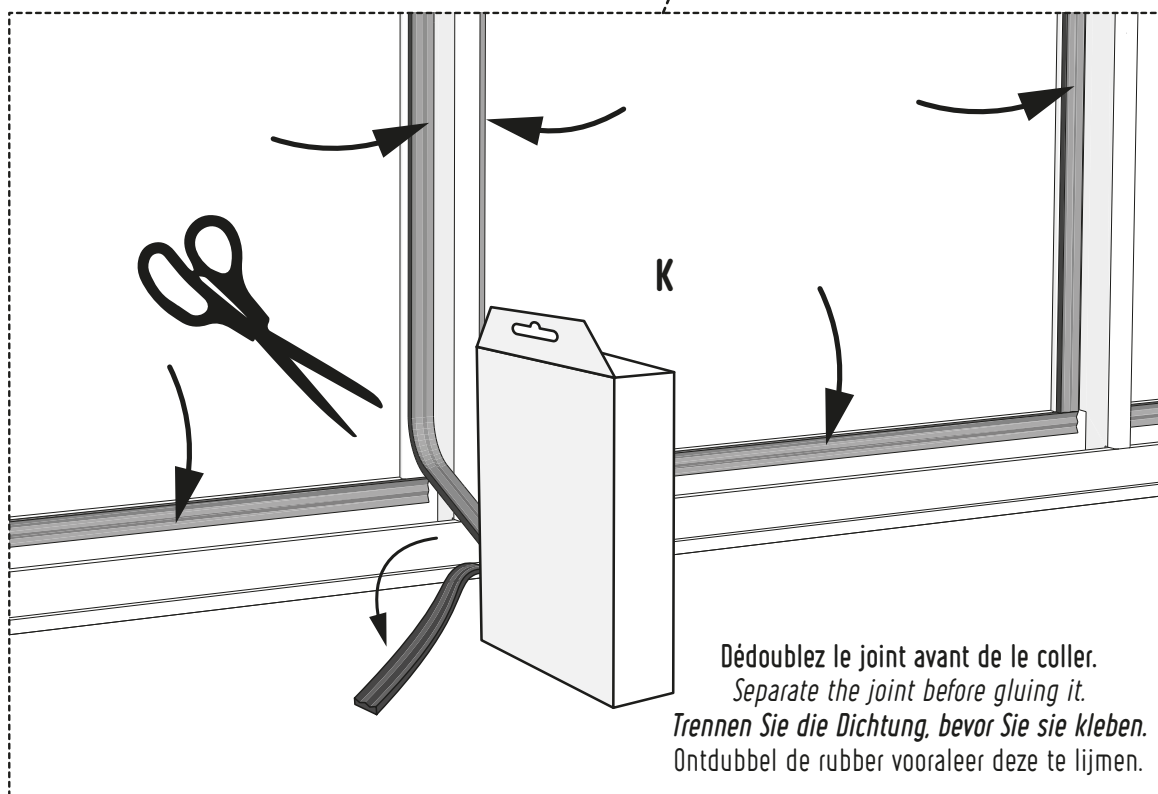
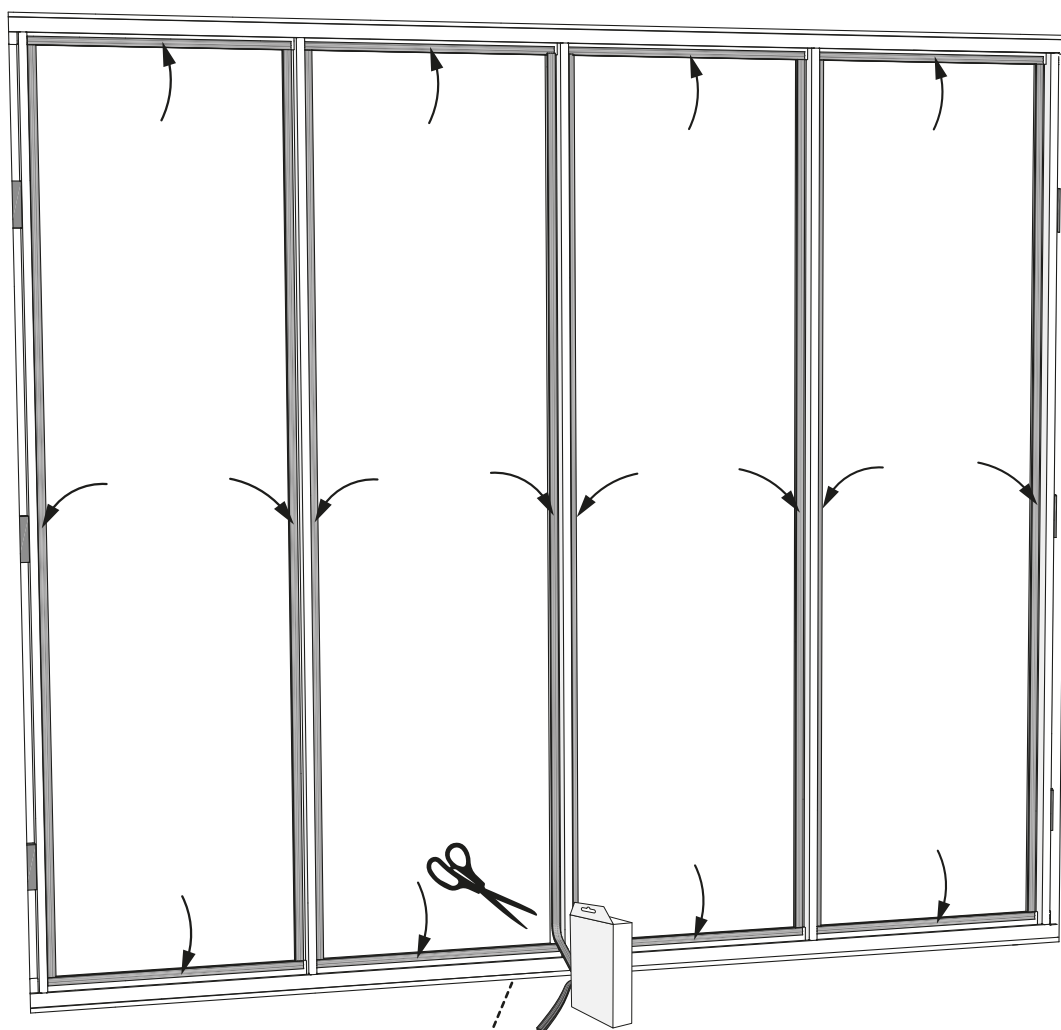

Alignement
Alignment
Ausrichtung
Uitlijning

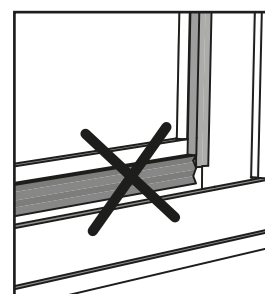
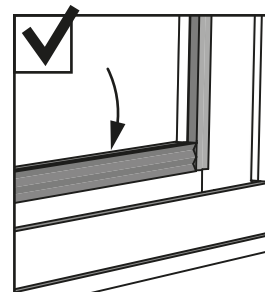

ÉTAPE 7 - STEP 7 - SCHRITT 7 - STAP 7

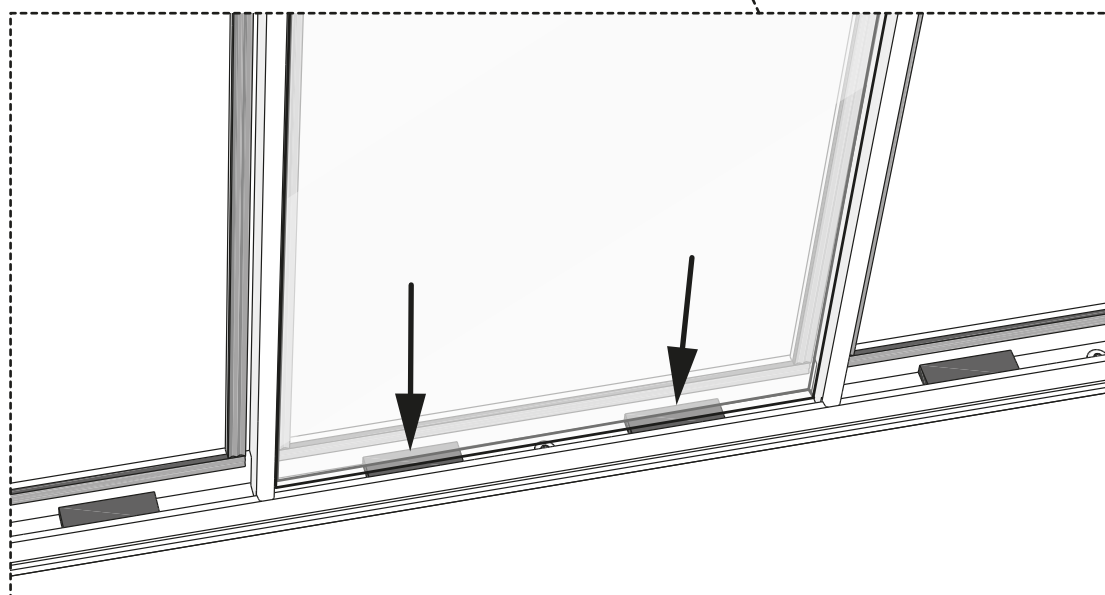
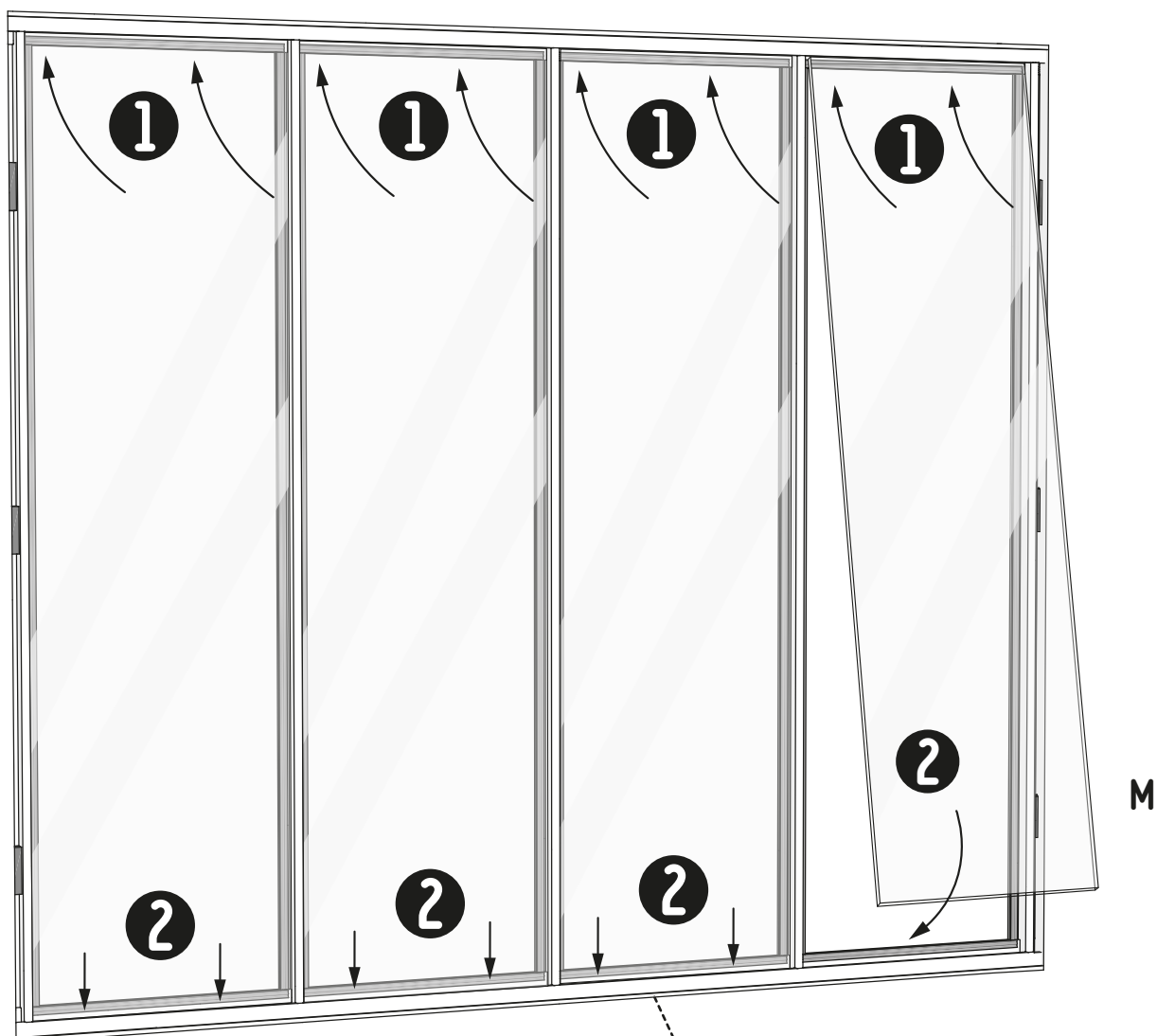

ÉTAPE 8 - STEP 8 - SCHRITT 8 - STAP 8

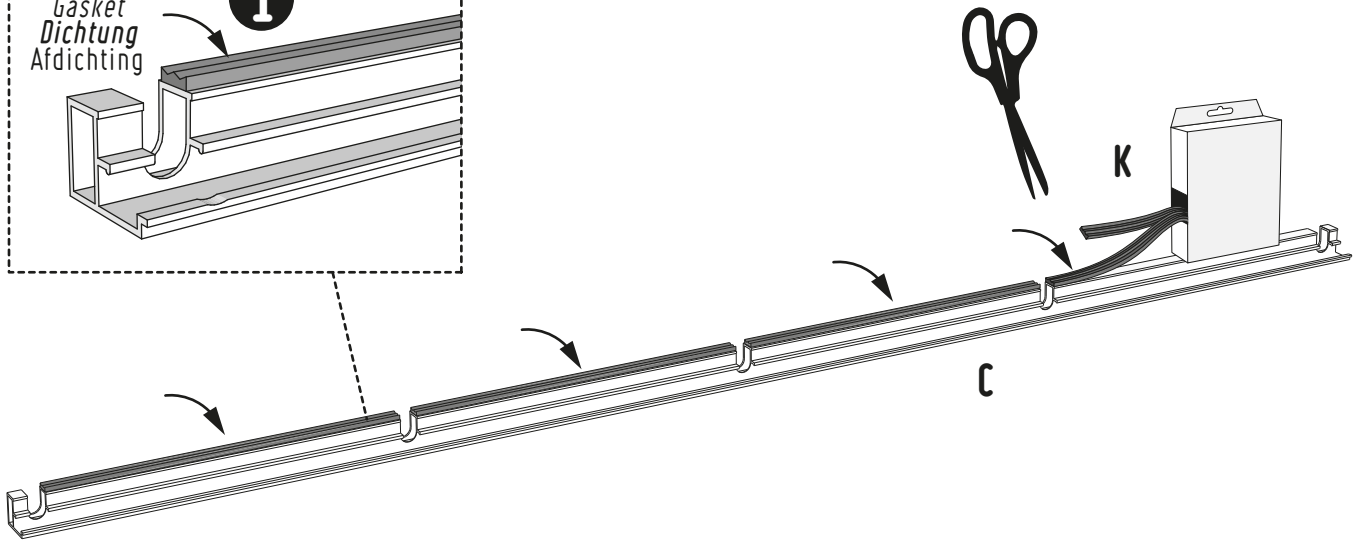
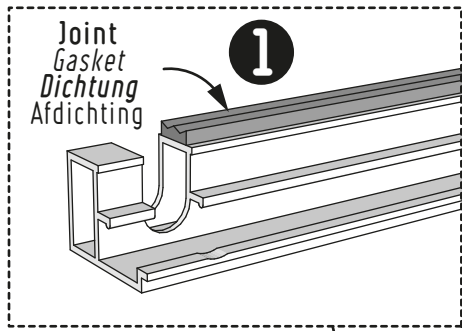

VUE DE PROFIL - PROFILE VIEW
PROFILANSICHT - ZIJAANZICHT

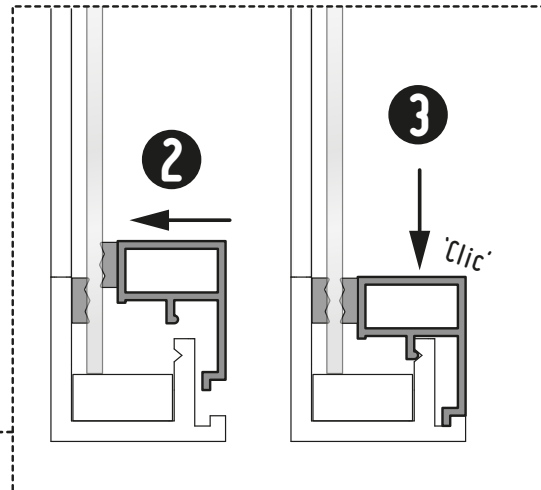
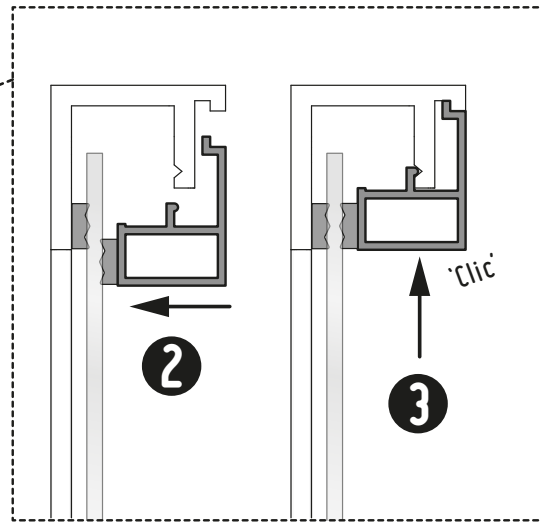
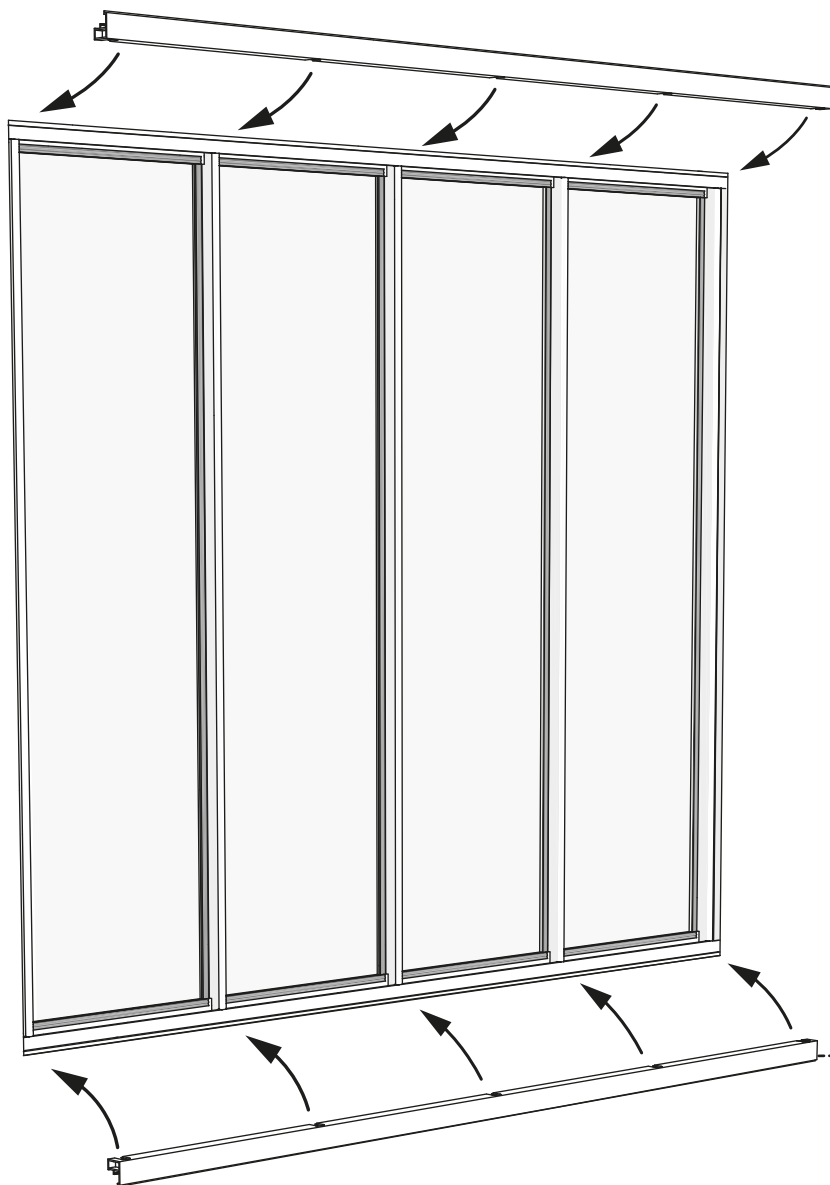

ÉTAPE 9 - STEP 9 - SCHRITT 9 - STAP 9

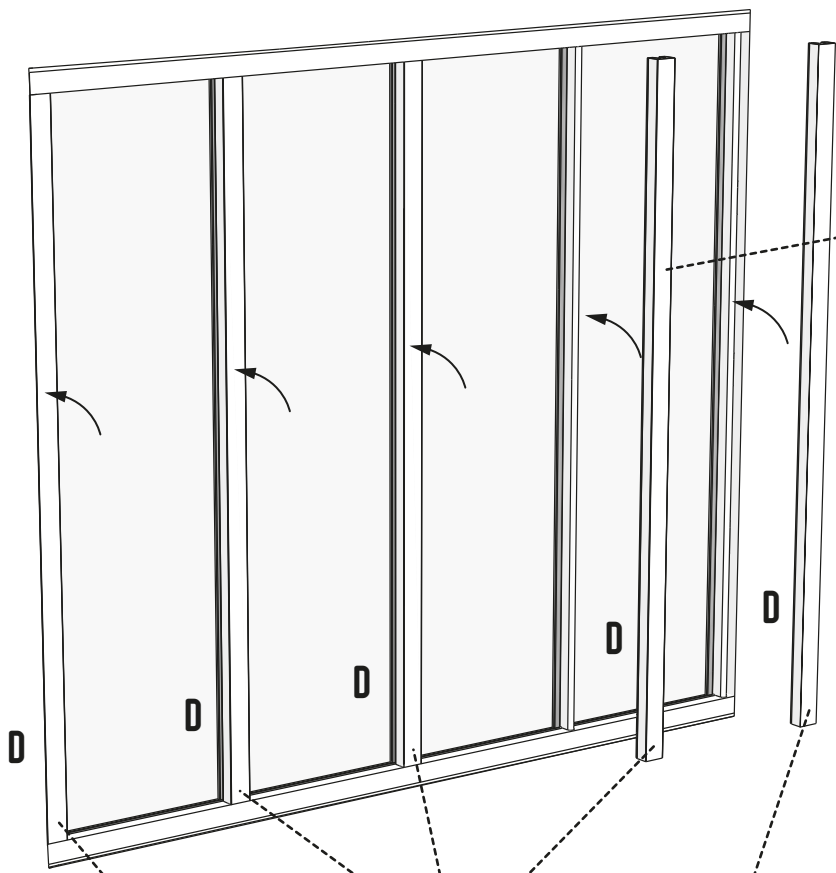
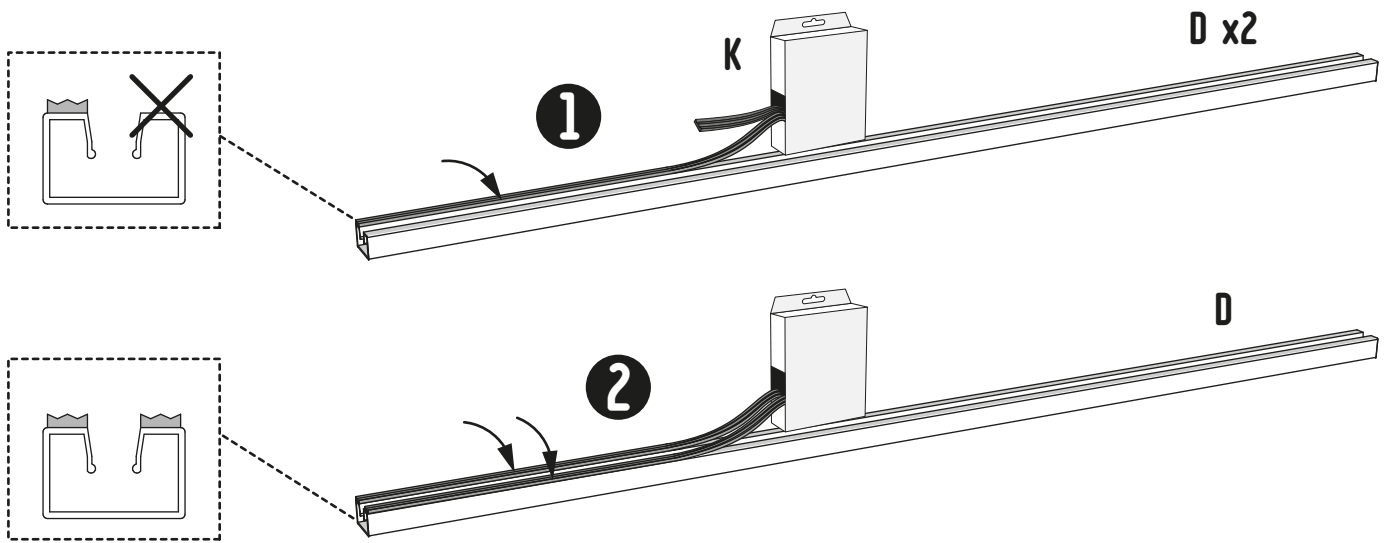

VUE DE DESSUS - TOP VIEW
ANSICHT VON OBEN - BOVENAANZICHT

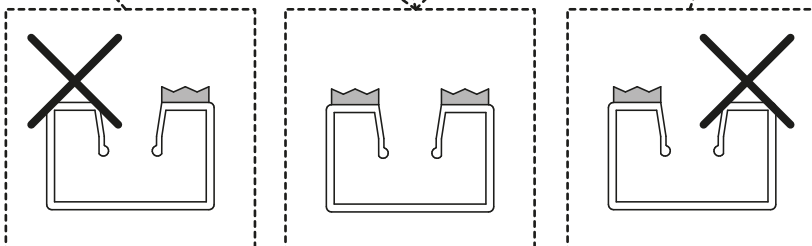
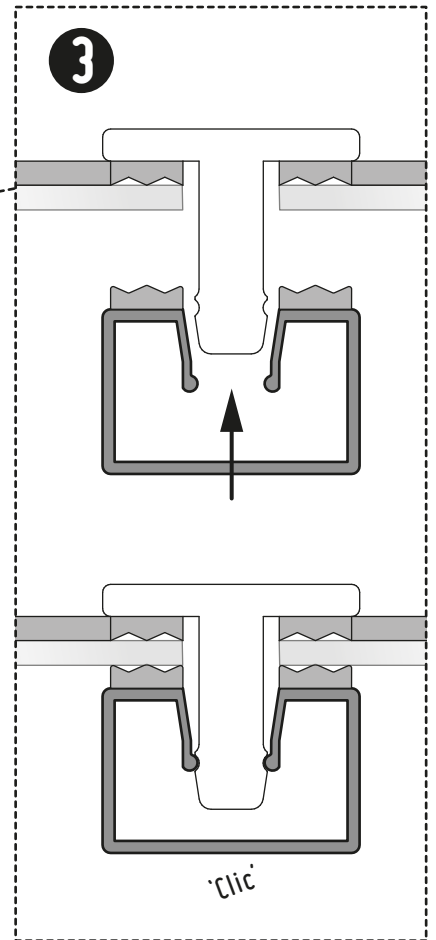

ÉTAPE 10 - STEP 10 - SCHRITT 10 - STAP 10

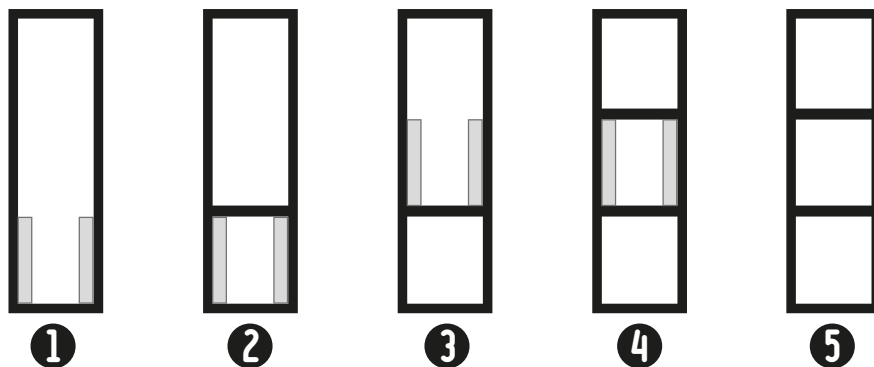
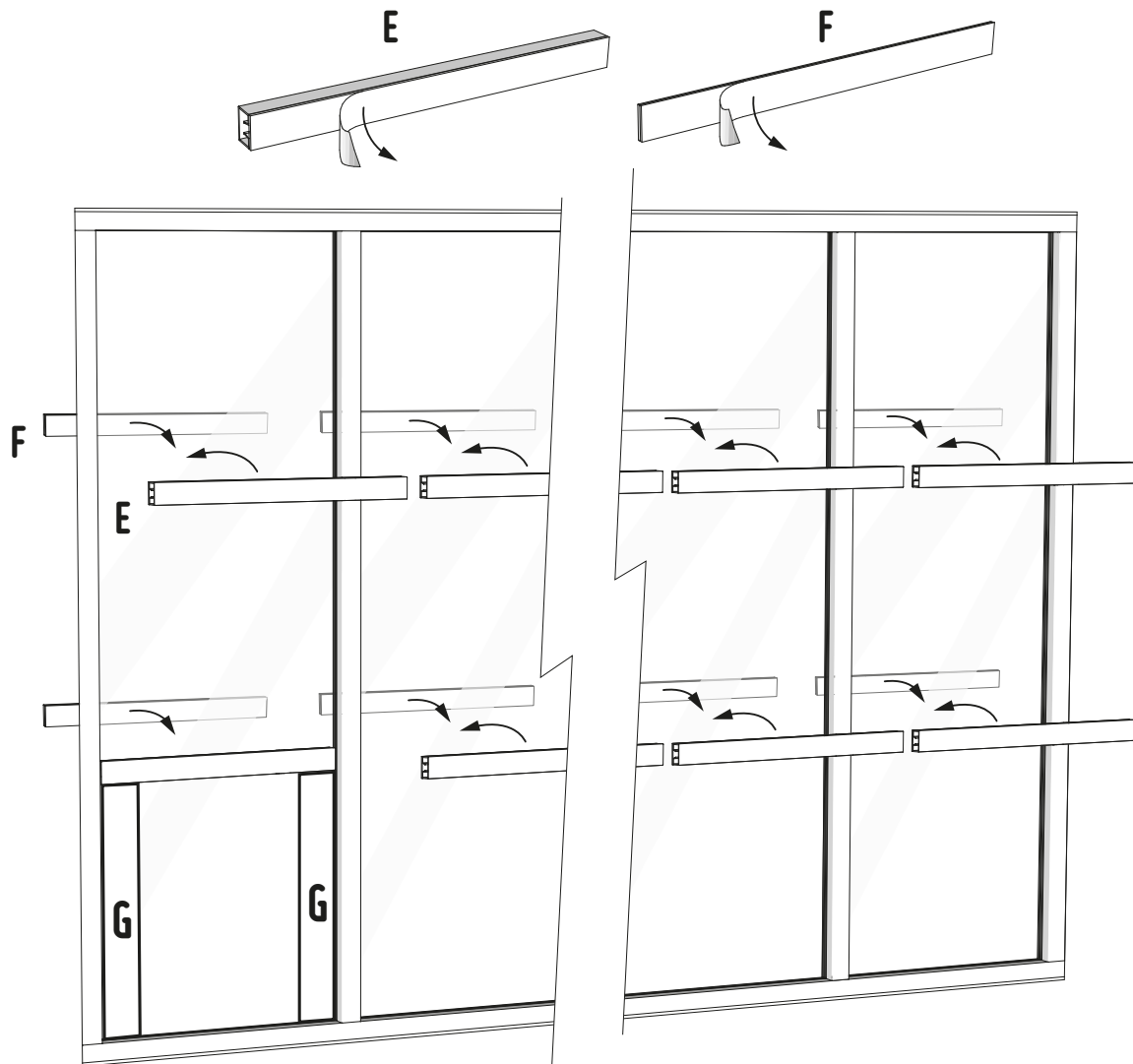

Positionnez les 2 gabarits puis collez un profil.
 Procédez de la même façon de l'autre côté du vitrage.
 Install the 2 gabarits as shown and glue a profile.
 Proceed the same way on the other side of the glass.
 Die 2 Abstandshalter positionieren, Profil kleben.
 Gehen Sie auf der anderen Seite der Verglasung genauso vor.
 Positioneer de 2 afstandshouders en kleef vervolgens een profiel.
 Ga verder op dezelfde manier aan de andere kant van het glas.



Les profils sont repositionnables seulement si vous exercez une légère pression. Pour une pose définitive, appuyez fortement.
 Profiles can only be repositioned if you exercise a slight pressure. For a final pose, press hard.
 Die Profile können nur bei leichtem Druck neu positioniert werden. Für eine endgültige Installation drücken Sie stark.
 De profielen kunnen enkel opnieuw worden gepositioneerd bij lichte druk. Hard drukken voor een definitieve bevestiging.